

Dear Editors and Reviewers,

We are very glad to receive your email with regard to our manuscript **se-2017-137**, entitled “**Influence of slope aspect on the microbial properties of rhizospheric and non-rhizospheric soil on the Loess Plateau, China**”. The comments from the reviewers are very helpful for revising and improving our manuscript, as well as hold great guiding significance to our researches. We take all of these comments into account in preparing the revised manuscript. We believe that the manuscript has been improved satisfactorily and hope it will be accepted for publication in **Solid Earth**.

The manuscript has been re-edited by an English editor, and some changes have taken place in the manuscript after re-editing. We thank again the Associate Editor and the reviewers for the helpful comments. If you require any further information, please contact with us at any times.

Anonymous Referee #1

General comments

The manuscript investigated the influence of slope aspects (southfacing, north-facing, and northeast-facing slopes, all with *Artemisia sacrorum* as the dominant species) on RS and NRS microbial biomass carbon (MBC) and phospholipid fatty acid (PLFA) contents, and the rhizospheric effect (RE) of various microbial indices. Using redundancy analysis (RDA) and path analysis, the authors quantified the driving factors controlling the rhizospheric soil (RS) and non-rhizospheric soil (NRS) microbial properties. I think the study is quite interesting, however, I think a total of 18 soil samples (3 sites 3 plots per site 2 soil types) were not enough for redundancy analysis, and the number of soil samples is not enough for evaluating the influence of slope aspect on the microbial properties of rhizospheric and non-rhizospheric soil, it will be perfect to take more soil samples at different slope gradient. Overall I think the paper will be of interest to soil readers. However, it needs considerable work, though, before it's ready for publication in the field. That work includes better organization of manuscript (especially Introduction section) and more sampling for the results. More importantly, The English in the paper needs considerable editing. Here are some more specific suggestions to improve the manuscript in a revised version.

R: We are very grateful to the reviewers for the recognition, and totally agree with the reviewer's comments. As the reviewer's comments, the plots in our paper were not very enough to explain the effect of slope aspect on the microbial properties of rhizospheric and non-rhizospheric soil, in a certain extent. However, the purpose of this paper was to emphasize that the slope aspect plays a key role in the study of rhizosphere microorganism, and to provide some new ideas for scientific research in a related field. In addition, the field survey in this paper was conducted in September 2014, so the plant community in the study area has now changed, looking for a new gradient of slope aspect was very difficult (other geographical factors as consistent as possible with the previous ones.) in the study area. Actually, we also tried to investigate more slope aspects in the investigation at 2014, but under the conditions of the same site conditions and plant species, the three slope aspects have been chosen in the paper: same site conditions, same dominant species, and geographical proximity. The location of the

three sites were marked in another article (Ai, Z. M., He, L. R., Xin, Q., et al. Slope aspect affects the non-structural carbohydrates and C: N: P stoichiometry of *Artemisia sacrorum* on the Loess Plateau in China, *Catena*, 152, 9-17, 2017). Figure was shown in the below, Fig. 1.



Fig. 1. The location of the experiment sites. ARSSWCCAS = An sai Research Station of Soil and Water Conservation of the Chinese Academy of Sciences.

To summarize, we hope that the reviewer consider the field test conditions, and give us a chance to express the standpoint in this article.

The paper has been re organized as suggested by the reviewer, especially the introduction part. This paper has been re-edited by the English editor. We are very grateful again to the reviewer for sincere comments, and these suggestions are very important to our future research work.

Specific comments

Lines 35: the first word “Slope aspect is an important topographic factor,” is not incomplete.

R: Considering the reviewer’s suggestion, we have changed this sentence into “Slope aspect is an important topographic factor in the micro-ecosystemic environment”. Lines 35

Line 55: the sentence “the angle between the ground and wind direction, which is defined as the orientation faced by a slope” can be deleted.

R: After carefully considered the reviewer’s suggestions, we have deleted this sentence. Line 59

Line 61-65: the sentences move to the behind of the first sentence of this paragraph, or suggest delete.

R: As suggested by the reviewer, we have already put this sentence to behind of the first sentence of this paragraph. Lines 61-65

Line 64- 69: the two sentences don’t connect well.

R: We totally agree with this comment, and apologize for our carelessness. We have added the new sentences between the “two sentences”: “Previous research indicated that slope aspect markedly affects soil and microbiological properties in micro-ecosystemic environments. The results of studies on the impact of slope aspect on the microbiological properties, however, are not consistent”. Lines 70-73

Line 68-72: suggest summarize these sentences.

R: As suggested by the reviewer, we have added a sentence in the manuscript: “The influence of slope aspect on microbial characteristics has obviously been variable in these studies, and the differences may be caused by the differences in plant species (trees vs shrubs), soil properties, climatic conditions, and research methods”. Lines 78-80

Line 70: unclear statement.

R: We have revised this sentence to make it clear: “other studies have found that the MBC, fungal, and total phospholipid fatty acid (PLFA) contents in the south-facing slopes were significantly higher than those in north-facing slopes”. Lines 75-77

Line 108-109: unclear statement.

R: We have rewritten this sentence to make it clear: “Under the conditions of different slope aspects, the effect of the main soil nutrient factors on RS and NRS microbial communities on local micro-ecosystemic environments, however, remains unclear”. Lines 115-117

Line 121-122: unclear statement.

R: We have rewritten this sentence to make it clear: “soil carbon (C) and nitrogen (N) are the main soil nutrient factors that affect RS and NRS microbial communities under different slope aspects”. Lines 129-130

Line 185: suggest “Impacts of slope aspects on...”

Line 192: suggest “Impacts of slope aspects on...”

R: As suggested by the reviewer, we have revised those in the manuscript. Lines 214, 224

Line 186-188: place the “Fig” in order.

R: We have placed the “Fig” in order in the manuscript. Lines 216-217

Line 232-235: unclear statement.

R: We have changed this sentence into “Among the seven environmental factors, WNO_3 content was the most significant and explained 34.7% ($P=0.04$) of the total variance”. Lines 261-263

Line 239, 245: “standardised path coefficients are shown in” suggest delete.

R: We agree with this suggestion and have deleted the “standardised path coefficients are shown in” in the manuscript. Lines 266, 273

Line 702: please give the full name of WSOC, SOC, SAP...

R: We are very sorry for our negligence and have added the full name of WSOC, SOC, SAP ... in the manuscript. Line 766

Anonymous Referee #2

Received and published: 7 February 2018

This paper is interesting and urgent in sense of microbial soil properties. The authors have investigated effect of slope aspect (south-facing, north-facing, and northeast-facing slopes) on the microbial properties of grassland rhizospheric and nonrhizospheric soils. The subject site was Ansai Research Station on the Loess Plateau in China. The authors have analyzed microbial biomass carbon, basal

respiration, substrate-induced respiration, phospholipid fatty acid contents and the rhizospheric effect. Moreover, statistics was used in the research (redundancy analysis and path analysis). The paper has a good organization, but the language is partly insufficient. It should be helpful to get the revision of a native English speaking person.

R: We are very grateful to the reviewer for the recognition and totally agree with the reviewer's comments. As suggested by the reviewer, the paper has been re-edited by the English editor.

Specific comments

I suggest several comments to improve the manuscript:

1. There is no explanation of the obtained results in the abstract - just briefly, in 1-2 sentences.

R: Considering the reviewer's suggestion, we have added a sentence in the abstract in the manuscript: "Soil samples were collected from the three slope aspects, including rhizospheric and non-rhizospheric region, and analyzed to determine the related various microbial indices. The results showed..." Lines 41-42

2. Please, pay attention to articles using in the text.

R: Thanks for the reviewer's reminding, we have paid more attention to them.

3. Line 57: "Solar radiation influences ON (?) ecologically critical factors..."

R: We have a confirmation that there is no "on" here after we communicated with our English editor. When "influence" is a noun, there will be an "on" on the back of "influence", and no "on" when "influence" is a verb. Line 59

4. Line 61: "which receive the more solar radiation..."

R: In accordance with the reviewer's suggestion, we have changed "receives" to "receive" in the manuscript. Line 62

5. In my opinion, it is worth to include to the introduction part the latest papers devoted to studied topic (2015-2017).

R: We agree with the reviewer's viewpoint. In order to control the number of references in the manuscript, three new references have been added in the manuscript: "Slope aspect can therefore substantially affect soil-moisture content, water budget, and soil temperatures (Dearborn and Danby, 2017)" and "The effect of slope aspect on basic soil properties (pH, bulk density, and texture), nutrient (carbon, nitrogen, and phosphorus) contents, microbial biomass, and enzymatic activities have been studied (Bardelli et al., 2017; Liu et al., 2017)." Lines 67, 70

6. Throughout the manuscript: please, don't use the pronoun "We" (for example, lines 114,116,117, 260, 262) – sentences should be impersonal.

R: We are very grateful to the reviewer's suggestion, and have deleted all the "We" in the manuscript.

7. Why did you investigate only 3 variants - south-facing, north-facing, and northeast-facing slopes? Why didn't you investigate west slopes? Was is the idea?

R: The suggestion is very meaningful. Actually, we also tried to investigate more slope aspects in the investigation at 2014 in the study area, but under the conditions of the same site conditions and plant species, the three slope aspects in the paper have met the conditions: same site conditions, same dominant species, and geographical proximity.

8. Hypotheses (1 and 2) should be written not in Future tense (would), but in Present.

R: Considering the reviewer's suggestion, we have changed the hypotheses to "(1) slope aspect significantly but differentially affects the MBC, total, fungal, bacterial, and actinomycete PLFA contents and their REs; and (2) soil carbon (C) and nitrogen (N) are the main soil nutrient factors that affect RS and NRS microbial communities under different slope aspects." Lines 127-130

9. Lines 121-122 – it is unclear – could you rephrase?

R: We have rewritten this sentence to make it clear: "soil carbon (C) and nitrogen (N) are the main soil nutrient factors that affect RS and NRS microbial communities under different slope aspects". Lines 129-130

10. Line 127: "annual temperature OF the study area is 8.8 °C,..."

R: We have revised it in the manuscript: "The mean annual temperature of the study area is 8.8 °C, ...". Lines 134-135

11. Section 2.1 Study site: Please provide the short review of natural soil and vegetation diversity in the region, close to the study plots, soil classification with references. Please, provide the detailed scheme/map of sampling sites putting sampling plots on it.

R: This suggestion is very meaningful to improve the manuscript. We have described the soil, vegetation, and map of sampling sites in another paper (Ai, Z. M., He, L. R., Xin, Q., et al. Slope aspect affects the non-structural carbohydrates and C: N: P stoichiometry of *Artemisia sacrorum* on the Loess Plateau in China, *Catena*, 152, 9-17, 2017). In order to reduce the text and length of this manuscript, we did not describe these again, and have added two sentences: "The main vegetation in the region includes woods such as *Robinia pseudoacacia* and *Platycladus orientalis*; shrubs such as *Caragana korshinskii*, *Hippophae rhamnoides*, *Syzygium aromaticum*, and *Ostryopsis davidiana*; and herbage such as *Artemisia sacrorum*, *Bothriochloa ischcemum*, *Setaria viridis*, *Artemisia giraldii*, and *Artemisia capillaris*." and "Details of the soil properties, and map of sampling sites were described by Ai et al. (2017)". Certainly, if the reviewer thinks it is necessary to describe these in this manuscript, we can add them. Lines 141-146

12. Line 129: Please, write a little bit more detail about abandoned areas – what happened and why, when it was and so on..

R: As suggested by the reviewer, we have added a few sentences in the manuscript: "To control soil erosion and improve the ecological environment, the Chinese government has implemented the policy of converting sloping cropland to grassland in the region in 1990s. Synchronously, restoration of the local grassland mainly dependent on abandoned farmland. In order to study the effect of slope aspect on the soil microbial community in the restored grassland, three grassland areas abandoned in the same year were selected for the experiment." Lines 137-141

13. Please, specify distance between sampling plots within sampling site and between them.

R: As suggested by the reviewer, we have added the sentence “The distance between sampling plots within sampling site was not less than 20 m” in the manuscript. Line 153

14. Are 18 soil samples enough to do the statistics that you have done?

R: This is a very good question. After consulting the researchers in the relevant major, all the co-authors of this manuscript believed that 18 soil samples are enough to do the statistics in a certain extent.

15. Section 2.3 Laboratory analysis: What are units of measure for MBC content, BR, SIR and metabolic content?

R: Considering the reviewer’s suggestion, we have added the units of measure for MBC content “(mg kg⁻¹)”, BR “(mg kg⁻¹ h⁻¹)”, SIR “(mg kg⁻¹ h⁻¹)” and metabolic content “(10³ h⁻¹)” in the manuscript. Lines 167-168

16. Line 158: Please, provide a detail formula for calculation a metabolic content (in order to understand units of measure).

R: As suggested by the reviewer, we have added the formula in the manuscript: “metabolic quotient=10³×BR/MBC=10³×(mg kg⁻¹ h⁻¹)/(mg kg⁻¹)”. Line 204

17. Lines 156-157: Please, provide more detail description of BR and SIR analysis (like MBC).

R: As suggested by the reviewer, we have added the determination method of BR and SIR in the manuscript: “The soil BR was estimated by measuring the CO₂ evolution from 10.0 g of field fresh soils. The homogenized soil samples were first placed in a polyethylene bottle with rubber stopper (the soil water content was adjusted to 50% of field water-holding capacity). The polyethylene bottle was then incubated at 28 °C for 2 h, and the CO₂ evolution was measured by an infrared gas analyser (QGS-08B, Beijing, China) (Hueso et al., 2011). Soil SIR was determined using the same method as for BR but with the addition of 0.06 g glucose to the soil, after the glucose and soil were fully compounded, they were then incubated at 28 °C for 1 h.” Lines 169-180

18. Lines 177-178: Please, write more detailed how RE was calculated, or give an example of calculation.

R: As suggested by the reviewer, we have added an example of calculation of RE: “For example, the RE for MBC: RE=RS MBC/NRS MBC=(mg kg⁻¹)/(mg kg⁻¹)”. Lines 206-207

19. Lines 187-188: it is unclear - RE in the south-facing slope was highest among the slope aspects – it is not for all studied properties.

R: We are very sorry for our negligence and have corrected it in our manuscript: “The RE for MBC in the south-facing slope was highest among the slope aspects”. Lines 216-217

20. Line 189: “... or SIR in either RS or NRS ...” – for SIR this statement is not true according to the Fig. 1B.

R: The statistical results of SIR in either RS or NRS indicated that there were no significant difference among different slope aspects ($P>0.05$). We apologize for confusing the reviewer by the figures, and we have re marked them in the manuscript.

21. Line 208: "... Total PLFA content in the north-facing slope was 50 and 62% higher than those..." – I suppose that 50 and 62% are incorrect – according to the Fig. 2B.

R: Total PLFA contents were 20.88 mg kg⁻¹ in the north-facing slope, 13.93 mg kg⁻¹ in the south-facing slope, and 12.89 mg kg⁻¹ in the northeast-facing slope, respectively. So the total PLFA content in the north-facing slope was 50 $((20.88-13.93)/13.93*100/100)$ and 62% $((20.88-12.89)/12.89*100/100)$ higher than those in the south- and northeast-facing slopes, respectively.

22. Line 213: "...G+ PLFA content did not differ significantly among the slope aspects (Fig. 2B)." – according to the Fig. 2B, it is not true.

R: The statistical results of G+ PLFA content indicated that there was no significant difference among different slope aspects ($P>0.05$). We apologize for confusing the reviewer by the figures, and we have re marked them in the manuscript.

23. Line 216: "... which were 49 and 117% higher..." – I suppose that 49 and 117% are incorrect? According to the Fig. 2B.

R: We are very sorry for our negligence. Actinomycete PLFA contents were 1.28 mg kg⁻¹ in the north-facing slope, 1.47 mg kg⁻¹ in the south-facing slope, and 0.59 mg kg⁻¹ in the northeast-facing slope, respectively. Actinomycete PLFA contents had higher contents in the south- and north-facing slopes, which were 149 $((1.47-0.59)/0.59*100/100)$ and 117% $((1.28-0.59)/0.59*100/100)$ higher, respectively, than that in the northeast-facing slope. We have revised it in the manuscript. Line 245

24. Lines 219-221: these two sentences can be summarized.

R: As suggested by the reviewer, we have merged these two sentences: "The REs for total, G+, G-, bacterial, actinomycete PLFA contents in the northeast-facing slope were highest among the slope aspects." Lines 248-250

25. Lines 173-175: you have measured several characteristics (pH, SAP, WSOC, and so on), but in results section there are no data. Could you, please, include a table or figure with these characteristics?

R: Considering the reviewer's suggestion, we have made a table for these characteristics and added it in the manuscript. Lines 201-202

Table 3. Characteristics of the rhizospheric and non-rhizospheric soils.

	Slope aspect	pH	Water Content (100%)	SOC (g kg ⁻¹)	SAP (mg kg ⁻¹)	NO ₃ (mg kg ⁻¹)	NH ₄ (mg kg ⁻¹)	WSOC (mg kg ⁻¹)	WNO ₃ (mg kg ⁻¹)	WNH ₄ (mg kg ⁻¹)
Rhizospheric soil	South-facing	8.55	7.73	9.20	3.23	8.60	12.94	59.12	1.55	0.61
	North-facing	8.72	10.37	7.36	2.41	9.70	9.87	37.02	1.27	0.44
	Northeast-facing	8.63	10.60	5.21	1.98	7.33	9.05	45.32	1.77	0.53
Non-rhizospheric soil	South-facing	8.54	8.13	5.53	1.35	4.93	12.32	38.14	1.20	0.50
	North-facing	8.58	10.31	4.90	1.37	6.73	13.13	36.47	0.98	0.38
	Northeast-facing	8.58	10.45	4.27	1.68	6.27	12.42	40.39	1.38	0.45

26. Line 275 "...supporting our hypothesis 2..." could you write it more precisely.

R: As suggested by the reviewer, we have revised the sentence in the manuscript: “supporting our hypothesis that soil C and N are the main soil nutrient factors that affect RS and NRS microbial communities”. Lines 303-304

27. Line 278: what do you mean- bioenergetic status - could you explain in your opinion?

R: Yes, the “bioenergetic status” here mainly refers to the status of utilization of energy substrates by soil microorganism, in particular, the energy change in the process of using soil organic carbon.

28. Line 291: “These different results may BE due to the differences”

R: As suggested by the reviewer, we have revised it in the manuscript: “These different results may be due to the differences....” Line 320

29. There is not so much discussion about north-east slopes in the text- could you add it?

R: As the change of soil microbial characteristics at northeast-facing slope were between north-facing and south-facing slopes, and the differences in soil microbial characteristics between north-facing and south-facing slopes were more obvious, so the discussion part paid more attention to north-facing and south-facing slopes.

30. Lines 318-319: this statement is not correct according to table 3.

R: We are very grateful to the reviewer’s conscientious, and very sorry for our carelessness. We have revised it in the manuscript: “The F/B ratio in our study was highest in the south-facing slope and lowest in the north-facing slope for both RS and NRS”. Lines 346-348

31. Line 315-324. If soil moisture is an important environmental factor affecting the composition of microbial communities, I suppose you should add your data of soil moisture to manuscript.

R: We agree with the reviewer’s viewpoint, but we have no monitoring data of soil moisture content in sampling sites. However, the soil moisture contents of sampling sites during our investigation have been added in the Table 3. Lines 201-202

Table 3. Characteristics of the rhizospheric and non-rhizospheric soils.

	Slope aspect	pH	Water Content (100%)	SOC (g kg ⁻¹)	SAP (mg kg ⁻¹)	NO ₃ (mg kg ⁻¹)	NH ₄ (mg kg ⁻¹)	WSOC (mg kg ⁻¹)	WNO ₃ (mg kg ⁻¹)	WNH ₄ (mg kg ⁻¹)
Rhizospheric soil	South-facing	8.55	7.73	9.20	3.23	8.60	12.94	59.12	1.55	0.61
	North-facing	8.72	10.37	7.36	2.41	9.70	9.87	37.02	1.27	0.44
	Northeast-facing	8.63	10.60	5.21	1.98	7.33	9.05	45.32	1.77	0.53
Non-rhizospheric soil	South-facing	8.54	8.13	5.53	1.35	4.93	12.32	38.14	1.20	0.50
	North-facing	8.58	10.31	4.90	1.37	6.73	13.13	36.47	0.98	0.38
	Northeast-facing	8.58	10.45	4.27	1.68	6.27	12.42	40.39	1.38	0.45

32. Sections 4.2.1 and 4.2.2 -please, analyze data of G⁺ and G⁻ PLFA contents either in section 4.2.1 or 4.2.2.

R: Considering the reviewer’s suggestion, we have added an analysis of G⁺ and G⁻ PLFA contents in section 4.2.1: “Previous studies have found that wetter soils are more enriched in G⁺ bacteria (Zhang et al., 2005; Drenovsky et al., 2010; Ma et al., 2015), in agreement with the result of the RE G⁺ PLFA content, but not the NRE G⁺ PLFA content. As RE was significantly affected by slope aspect for the G⁺

PLFA content, this may be one of the reasons that caused the difference between RE and NRE G^+ PLFA contents. Furthermore, the RDA indicated that the RS WSOC was well correlated with the RE G^+ PLFA content, and the NRS WNH_4 content was well correlated with the NRE G^+ PLFA content (Fig. 4A, B). Although drier soils tend to be more enriched in G^- bacteria (Zhang et al., 2005; Drenovsky et al., 2010; Ma et al., 2015), both the higher RE and NRE G^- PLFA contents were recorded at the north-facing slope. It has been shown that drier soils can lead to low root exudates, which may lead to lower activities of the soil microorganisms (Zhang et al., 2015).” Lines 357-367

33. Line 339-340: “NRS actinomycete PLFA content, however, was lower in the northeast-facing slope than that in the south-facing slope.”- but also - than in the north-facing slope, or not?

R: Yes, it is. Considering the reviewer’s suggestion, we have revised the sentence to be: “NRS actinomycete PLFA content, however, was lower in the northeast-facing slope than those in the north-facing and south-facing slopes.” Line 376-377

34. Lines 347-348: “Drier soils tend to be more enriched in G- bacteria and fungi,...”? it is not correct according to fig. 2.

R: We are very grateful to the reviewer’s reminding, and have deleted the sentence.

35. Line 408: the surname SCHAEPMAN~ARSTRUB should be written in lower case.

R: As suggested by the reviewer, we have revised it in the manuscript: “Schaezman - strub”.

36. Journal names should be abbreviated according to the ISI Journal Title Abbreviations Index (according to Manuscript preparation guidelines for authors).

R: We are very grateful to the reviewer’s reminding, and the journal names have been abbreviated in the manuscript. For example, Anderson, T.-H., and Domsch, K.: The metabolic quotient for CO_2 (qCO_2) as a specific activity parameter to assess the effects of environmental conditions, such as pH, on the microbial biomass of forest soils, *Soil Biol. Biochem.*, 25, 393-395, doi:10.1016/0038-0717(93)90140-7, 1993.

37. Please, add DOI to references.

R: As suggested by the reviewer, we have added the DOI to references in the manuscript. For example, Anderson, T.-H., and Domsch, K.: The metabolic quotient for CO_2 (qCO_2) as a specific activity parameter to assess the effects of environmental conditions, such as pH, on the microbial biomass of forest soils, *Soil Biol. Biochem.*, 25, 393-395, doi:10.1016/0038-0717(93)90140-7, 1993.

38. The quality of Figures 2 and 3 is very poor. Nothing is clear at the picture. Please make columns larger and readable. Could you explain what different letters above the bars (a, b, ab) mean? And when there are no letters? what does it mean? (fig. 1-3).

R: Considering the reviewer’s suggestion, we have split Figure 2 into 3 figures, and Figure 3 into 4 figures to improve their readability. Different letters above the bars in the figures indicate significant differences at $P=0.05$. For example, in Figure 1A, NRS MBC content in the north-facing slope was higher than those in the south- and northeast-facing slopes, and there was no significant difference between south-facing slope and northeast-facing slope, so the letter above the column of north-facing slope was a, both the letters above the columns of north- and northeast-facing slopes were b.

We are sorry for making the reviewer confused. We have added the same letter (a) above the bars that had no letters before in all figures, and the same letters meant that there was no difference among the slope aspects.

39. Figure 4: RQ (respiratory quotient) ?what is it? Please, make this figure larger and readable.

R: The respiratory quotient was BR/MBC. We have changed the “RQ” to “BR/MBC” in Figure 4.

To improve its readability, Figure 4 has re plotted and rearranged.

Nevertheless, I found this paper of good quality and after correcting it can be publish.

R: Once again, we thank the reviewer for the positive comments, and we have revised the manuscript in accordance with reviewer’s suggestions.

- Bardelli, T., Gómez-Brandón, M., Ascher-Jenull, J., Fornasier, F., Arfaioli, P., Francioli, D., Egli, M., Sartori, G., Insam, H., and Pietramellara, G.: Effects of slope exposure on soil physico-chemical and microbiological properties along an altitudinal climosequence in the Italian Alps, *Sci. Total Environ.*, 575, 1041-1055, doi:10.1016/j.scitotenv.2016.09.176, 2017.
- Dearborn, K. D., and Danby, R. K.: Aspect and slope influence plant community composition more than elevation across forest–tundra ecotones in subarctic Canada, *Journal of Vegetation Science*, 28, 595-604, doi:10.1111/jvs.12521, 2017.
- Drenovsky, R. E., Steenwerth, K. L., Jackson, L. E., and Scow, K. M.: Land use and climatic factors structure regional patterns in soil microbial communities, *Global Ecol. Biogeogr.*, 19, 27-39, doi:10.1111 / j.1466-8238.2009.00486.x, 2010.
- Liu, M., Zheng, R., Bai, S., and Wang, J.: Slope aspect influences arbuscular mycorrhizal fungus communities in arid ecosystems of the Daqingshan Mountains, Inner Mongolia, North China, *Mycorrhiza*, 27, 189-200, doi:10.1007/s00572-016-0739-7 2017.
- Ma, L. N., Guo, C. Y., Lü X. T., Yuan, S., and Wang, R. Z.: Soil moisture and land use are major determinants of soil microbial community composition and biomass at a regional scale in northeastern China, *Biogeosciences*, 12, 2585-2596, doi:10.5194/bg-12-2585-2015, 2015.
- Zhang, C., Liu, G. B., Xue, S., and Wang, G. L.: Changes in rhizospheric microbial community structure and function during the natural recovery of abandoned cropland on the Loess Plateau, China, *Ecol. Eng.*, 75, 161-171, doi:10.1016/j.ecoleng.2014.11.059, 2015.
- Zhang, W., Parker, K., Luo, Y., Wan, S., Wallace, L., and Hu, S.: Soil microbial responses to experimental warming and clipping in a tallgrass prairie, *Global Change Biol.*, 11, 266-277, doi:10.1111/j.1365-2486.2005.00902.x, 2005.

Feb 22, 2018

Solid Earth

Dear Editor and Reviewers,

This letter certifies that I have edited the language of the manuscript entitled “Influence of slope aspect on the microbial properties of rhizospheric and non-rhizospheric soil on the Loess Plateau, China”. The language of the manuscript should meet your standards.

Sincerely,

Dr. William Blackhall

Editor, Global Biological Editing

editor@globalbiologicalediting.com

www.globalbiologicalediting.com

1 **Influence of slope aspect on the microbial properties of rhizospheric**
2 **and non-rhizospheric soil on the Loess Plateau, China**

3
4 Ze Min Ai ^{1,2,3}, Jiao Yang Zhang ^{1,2,3}, Hong Fei Liu ⁴, Sha Xue ^{1,2*}, Guo Bin Liu ^{1,2}
5
6
7

8
9
10
11 ¹ State Key Laboratory of Soil Erosion and Dryland Farming on the Loess Plateau, Institute of Soil and
12 Water Conservation, Northwest A&F University, Yangling, 712100, People's Republic of China

13 ² Institute of Soil and Water Conservation, Chinese Academy of Sciences & Ministry of Water
14 Resources, Yangling, Shaanxi 712100, People's Republic of China

15 ³ University of Chinese Academy of Sciences, Beijing 100101, People's Republic of China

16 ⁴ College of Forestry, Northwest A&F University, Yangling, Shaanxi 712100, People's Republic of
17 China

18
19
20
21
22
23
24 * Corresponding author.

25 E-mail address: xuesha100@163.com.

26 *Corresponding address: Xinong Rd. 26, Institute of Soil and Water Conservation, Northwest A&F
27 University, Yangling, Shaanxi 712100, People's Republic of China.

35 **Abstract.** Slope aspect is an important topographic factor in the micro-ecosystemic environment, but
36 its effect on the microbial properties of grassland rhizospheric soil (RS) and non-rhizospheric soil
37 (NRS) remain unclear. A field experiment was conducted at the Ansai Research Station on the Loess
38 Plateau in China to test the influence of slope aspects (south-facing, north-facing, and northeast-facing
39 slopes, all with *Artemisia sacrorum* as the dominant species) on RS and NRS microbial biomass carbon
40 (MBC) content, phospholipid fatty acid (PLFA) content, and the rhizospheric effect (RE) of various
41 microbial indices. Soil samples were collected from the three slope aspects, including rhizospheric and
42 non-rhizospheric region, and analyzed to determine the related various microbial indices. The results
43 showed that MBC content differed significantly among the slope aspects in RS but not in NRS, and RE
44 for MBC content in the south-facing slope was larger than that in the north-facing slope. RS total,
45 bacterial, and gram-positive bacterial PLFA contents in the south-facing slope were significantly lower
46 than those in the north- and northeast-facing slopes, and RS gram-negative bacterial (G⁻) and
47 actinomycete PLFA contents in the south-facing slope were significantly lower than those in the
48 north-facing slope. In contrast, NRS total, bacterial, and G⁻ PLFA contents in the north-facing slope
49 were significantly higher than those in the south- and northeast-facing slopes, and NRS fungal and
50 actinomycete PLFA contents in the north- and south-facing slopes were significantly higher than those
51 in the northeast-facing slope. RE for all PLFA contents except fungal in the northeast-facing slope were
52 higher than those in the south-facing slope. Slope aspect significantly but differentially affected the
53 microbial properties in RS and NRS, and the variable influence was due to an evident RE for most
54 microbial properties.

55 **Keywords:** topographic factor, rhizospheric effect, phospholipid fatty acid, fungi, bacteria,
56 actinomycete

57 1 Introduction

58 As an important topographic factor, slope aspect can affect the amount of solar radiation received
59 (Selvakumar et al., 2009), and solar radiation influences ecologically critical factors of local
60 microclimates and determines soil temperature, evaporation capacity, and soil-moisture content
61 (Carletti et al., 2009; Bennie et al., 2008). South-facing slopes in the Northern Hemisphere, which
62 receive more solar radiation than north-facing slopes, are typically hot, dry, and subject to rapid
63 changes in seasonal and diurnal microclimates. North-facing slopes have the opposite pattern and
64 receive the least insolation, are cool, moist, and subject to slow changes in seasonal and daily
65 microclimates (Sariyildiz et al., 2005). Slope aspect can therefore substantially affect soil-moisture
66 content, water budget, and soil temperatures (Sidari et al., 2008; Carletti et al., 2009; Sariyildiz et al.,
67 2005; Dearborn and Danby, 2017). The effect of slope aspect on basic soil properties (pH, bulk density,
68 and texture), nutrient (carbon, nitrogen, and phosphorus) contents, microbial biomass, and enzymatic
69 activities have been studied (Ai et al., 2017a; Ascher et al., 2012; Gilliam et al., 2014; Huang et al.,
70 2015; Sidari et al., 2008; Qin et al., 2016; Bardelli et al., 2017; Liu et al., 2017). Previous research
71 indicated that slope aspect markedly affects soil and microbiological properties in micro-ecosystemic
72 environments. The results of studies on the impact of slope aspect on the microbiological properties,
73 however, are not consistent. Some studies have shown that north-facing slopes have more microbial
74 biomass carbon (MBC), bacteria, and actinomycetes than south-facing slopes (Ascher et al., 2012;
75 Huang et al., 2015); in contrast, other studies have found that the MBC, fungal, and total phospholipid
76 fatty acid (PLFA) contents in the south-facing slopes were significantly higher than those in

77 north-facing slopes (Huang et al., 2015; Sidari et al., 2008; Gilliam et al., 2014). Gilliam et al. (2014)
78 found that bacterial biomass did not vary with slope aspect. The influence of slope aspect on microbial
79 characteristics has obviously been variable in these studies, and the differences may be caused by the
80 differences in plant species (trees vs shrubs), soil properties, climatic conditions, and research methods.
81 Previous studies have mainly focused on trees and shrubs, but the influence of slope aspect on
82 grassland soil microorganisms is still unclear, even though the grassland ecosystem is an important
83 component of terrestrial ecosystems.

84 The rhizosphere is commonly defined as the narrow zone of soil adjacent to and influenced by
85 plant roots (Chen et al., 2002). The rhizosphere contains root exudates, i.e. leaked and secreted
86 chemicals, sloughed root cells, and plant debris (Warembourg et al., 2003). Microbial activity is
87 therefore high in rhizospheric soil (RS) and clearly distinct from the activity in non-rhizospheric soil
88 (NRS) due to differences in nutrient availability, pH, and redox potential (Hinsinger et al., 2009).
89 Microbial content is higher in RS than NRS (Buyer et al., 2002; Marschner et al., 2002), which is
90 known as the rhizospheric effect (RE). The effect of slope aspect on RS and NRS microbial biomass
91 and community composition has not been extensively studied. Knowledge of the influence of slope
92 aspect on the differences between RS and NRS microbial communities could provide new insights into
93 topographical influences of RE on local micro-ecosystemic environments.

94 Soil microbial communities play important roles in soil quality and ecosystemic processes,
95 including nutrient cycling, decomposition of organic matter, bioremediation of structural formation,
96 and even plant interactions (Harris, 2009). These communities are closely associated with their
97 surroundings, rapidly responding to changes and environmental stresses. Soil microbes are thus
98 commonly used as sensitive indicators of change to soil quality under environmental stresses. Various
99 microbial PLFAs represent the different nutritional requirements of the microbial groups. Bacteria and
100 fungi form most of the microbial biomass and represent the main drivers of organic-matter turnover
101 (Bååth and Anderson, 2003). Moreover, different kinds of bacteria produce different PLFAs:
102 Gram-negative (G^-) and Gram-positive (G^+) bacterial PLFA contents are usually considered indicators
103 of chemolithotrophic and heterotrophic bacterial communities, respectively. G^- bacteria are mainly
104 associated with roots and thus decompose low-molecular-weight organic molecules (Griffiths et al.,
105 1999), whereas G^+ bacteria decompose more complex materials, such as organic matter and litter
106 (Kramer and Gleixner, 2006). Soil respiration is widely used for measuring microbial activity (e.g.
107 basal respiration) or determining the potential microbial activity in soil (e.g. substrate-induced
108 respiration) (Nannipieri et al., 1990; Wardle, 1995). These microbial indices are all sensitive
109 bio-indicators that can be used to estimate soil quality and the effect of slope aspect on RS and NRS
110 microbial communities. Soil ecologists have long been interested in the response of microbial
111 communities to environmental factors for understanding the underlying mechanisms determining the
112 content and composition of microbial biomass. Microbial communities have a close relationship with
113 pH, carbon (organic and water-soluble organic carbon), nitrogen (total nitrogen, ammonium and nitrate
114 nitrogen, and water-soluble ammonium and nitrate nitrogen), and phosphorus (total and available
115 phosphorus) (Bardelli et al., 2017; Huang et al., 2014; Nilsson et al., 2005; Ma et al., 2015). Under the
116 conditions of different slope aspects, the effect of the main soil nutrient factors on RS and NRS
117 microbial communities on local micro-ecosystemic environments, however, remains unclear.

118 The Chinese government introduced the Grain for Green Project in the 1990s to control soil
119 erosion and improve the ecological environment of the Loess Plateau by converting large areas of
120 sloping cropland to forest and grassland. *Artemisia sacrorum*, a perennial herb with multiple branches,

121 well-developed root suckers, and high seed production and fertility, is widely distributed on the plateau
 122 (Wang and Liu, 2002), especially in the converted grassland. *A. sacrorum* was selected as a typical
 123 grassland plant of this region to study the effect of slope aspect on the MBC, total, fungal, bacterial,
 124 and actinomycete PLFA contents in RS and NRS and the differences of their REs. The main RS and
 125 NRS environmental factors affecting microbial content and composition were also identified. Three
 126 slope aspects (south-facing, north-facing, and northeast-facing slopes) with the same rehabilitation age
 127 were tested on the Loess Plateau in China. The following hypotheses were tested: (1) slope aspect
 128 significantly but differentially affects the MBC, total, fungal, bacterial, and actinomycete PLFA
 129 contents and their REs; and (2) soil carbon (C) and nitrogen (N) are the main soil nutrient factors that
 130 affect RS and NRS microbial communities under different slope aspects.

131 2 Materials and methods

132 2.1 Study site

133 A field experiment was conducted at the Ansai Research Station (ARS) of the Chinese Academy of
 134 Sciences (36°51'30"N, 109°19'23"E; 1068–1309 m a.s.l.), northern Loess Plateau, China. The mean
 135 annual temperature of the study area is 8.8 °C, and the mean annual precipitation is approximately 505
 136 mm, with >70% concentrated from July to September. Annual evaporation ranges from 1500 to 1800
 137 mm. To control soil erosion and improve the ecological environment, the Chinese government has
 138 implemented the policy of converting sloping cropland to grassland in the region in 1990s.
 139 Synchronously, restoration of the local grassland mainly dependent on abandoned farmland. In order to
 140 study the effect of slope aspect on the soil microbial community in the restored grassland, three
 141 grassland areas abandoned in the same year were selected for the experiment. The main vegetation in
 142 the region includes woods such as *Robinia pseudoacacia* and *Platycladus orientalis*; shrubs such as
 143 *Caragana korshinskii*, *Hippophae rhamnoides*, *Syzygium aromaticum*, and *Ostryopsis davidiana*; and
 144 herbage such as *Artemisia sacrorum*, *Bothriochloa ischaemum*, *Setaria viridis*, *Artemisia giraldii*, and
 145 *Artemisia capillaris*. Details of the soil properties and map of sampling sites were described by Ai et al.
 146 (2017a).

147 2.2 Experimental design and soil sampling

148 The slopes of the three grassland areas were south-facing (S15 °W), northeast-facing (N75 °W), and
 149 north-facing (N57 °E). The three study areas were selected in September 2014 after consultation with
 150 ARS researchers and reviewing relevant land documents. The basic characteristics are shown in Table 1.

151 **Table 1.** Characteristics of the sampling sites.

Slope aspect	Latitude (°N)	Longitude (°E)	Altitude (m)	Plant community
S15 °W	36.85	109.31	1269	<i>A. sacrorum</i> + <i>Bothriochloa ischaemum</i>
N75 °W	36.85	109.31	1275	<i>A. sacrorum</i> + <i>Phragmites australis</i>
N57 °E	36.85	109.31	1278	<i>A. sacrorum</i> + <i>Artemisia capillaries</i>

152 Three replicate 10 × 10 m plots were established at each site (*A. sacrorum* was the dominant plant
 153 at each site). The distance between sampling plots within sampling site was not less than 20 m. Each
 154 plot was first surveyed for latitude, longitude, elevation, slope aspect, and slope gradient. Three 1 × 1
 155 m quadrats were then randomly set in each plot to characterise the vegetation, e.g. plant species,
 156 coverage, and number. The plants were removed, and the soil strongly adhering to the roots, i.e. RS,
 157 was collected (0–20 cm soil layer). Soil was also sampled from the same layer at locations

158 approximately 15 cm from the plant roots (i.e. NRS). Each NRS sample was a composite of
 159 subsamples collected at five points (the four corners and the centre of the plot). A total of 18 soil
 160 samples (3 sites \times 3 plots per site \times 2 soil types) were collected, and each was divided into two
 161 subsamples: one subsample was placed in a cool container, and the other was placed into a cloth bag.
 162 The samples were then taken to the laboratory, and gravel and coarse fragments were removed. The
 163 container samples were homogenised and sieved to 2 mm and were also divided into two subsamples:
 164 one subsample was stored at -80 °C, and the other was stored at 4 °C until analysis. The samples in the
 165 cloth bags were air-dried and sieved to 0.25 and 1 mm prior to analysis.

166 2.3 Laboratory analysis

167 The samples stored at 4 °C were used for determining MBC content (mg kg^{-1}), basal respiration (BR)
 168 ($\text{mg kg}^{-1} \text{h}^{-1}$), and substrate-induced respiration (SIR) ($\text{mg kg}^{-1} \text{h}^{-1}$). Microbial biomass was measured
 169 by chloroform fumigation (Vance et al., 1987). The soil samples were fumigated for 24 h at 25.8 °C
 170 with CHCl_3 (ethanol free) after the fumigation or non-fumigation treatments and then were extracted
 171 with 100 ml of 0.5 M K_2SO_4 by horizontal shaking for 1 h at 200 rpm and then filtered. The amount of
 172 K_2SO_4 -extracted organic C was determined by a liquiTOCII analyser (Elementar, Hanau, Germany),
 173 and MBC content was calculated using a kEC factor of 0.38 (Vance et al., 1987). The soil BR was
 174 estimated by measuring the CO_2 evolution from 10.0 g of field fresh soils. The homogenized soil
 175 samples were first placed in a polyethylene bottle with rubber stopper (the soil water content was
 176 adjusted to 50% of field water-holding capacity). The polyethylene bottle was then incubated at 28 °C
 177 for 2 h, and the CO_2 evolution was measured by an infrared gas analyser (QGS-08B, Beijing, China)
 178 (Hueso et al., 2011). Soil SIR was determined using the same method as for BR but with the addition of
 179 0.06 g glucose to the soil, after the glucose and soil were fully compounded, they were then incubated
 180 at 28 °C for 1 h.

181 The soil stored at -80 °C was used for the determination of PLFA contents. The structures of the
 182 microbial communities were determined using a method (Bligh and Dyer, 1959) modified by Bardgett
 183 et al. (1996). Briefly, fatty acids were extracted from 3.0 g of freeze-dried soil using a solution
 184 containing citrate buffer, chloroform, and methanol. The PLFAs were separated from neutral and
 185 glycolipid fatty acids by solid-phase-extraction chromatography. After mild alkaline methanolysis, the
 186 PLFAs were analysed using a gas chromatograph (GC7890A, Agilent Technologies Inc., Wilmington,
 187 USA) equipped with MIDI Sherlock software (Version 4.5; MIDI Inc., Newark, USA).

188 **Table 2. Characterisation of the microbial phospholipid fatty acids.**

Microbial group	Specific PLFA markers
Gram-positive bacteria	11:0 anteiso, 12:0 anteiso, 13:0 iso, 13:0 anteiso, 14:0 iso, 14:0 anteiso, 15:0 iso, 15:0 anteiso, 15:1 iso w6c, 15:1 iso w9c, 16:0 iso, 16:0 anteiso, 17:0 iso, 17:0 anteiso, 18:0 iso, 19:0 iso, 19:0 anteiso, 22:0 iso
Gram-negative bacteria	12:1 w4c, 12:1 w8c, 14:1 w5c, 14:1 w8c, 14:1 w9c, 15:1 w5c, 15:1 w7c, 15:1 w8c, 16:1 w7c DMA, 16:1 w7c, 16:1 w9c DMA, 17:0 cyclo w7c, 17:1 w5c, 17:1 w7c, 17:1 w8c, 18:1 w5c, 18:1 w6c, 18:1 w7c, 18:1 w8c, 18:1 w9c, 19:0 cyclo w6c, 19:0 cyclo w7c, 19:1 w6c, 19:1 w8c, 20:1 w6c, 20:1 w9c, 21:1 w3c, 21:1 w5c, 21:1 w6c, 22:1 w3c, 22:1 w5c, 22:1 w6c, 22:1 w8c, 22:1 w9c, 24:1 w9c, 19:0 cyclo 9,10 DMA
Fungi	16:1w5c, 18:2w6c
Actinomycetes	16:0 10-methyl, 17:0 10-methyl, 17:1 w7c 10-methyl, 18:0 10-methyl, 18:1 w7c 10-methyl, 19:1 w7c 10-methyl, 20:0 10-methyl

189 An external standard of 19:0 methyl ester was used for quantification (Frostegård et al., 1993),
 190 and the amounts were expressed as nmol g⁻¹ for dry soil. Zelles (1999) reported that specific PLFA
 191 signatures could serve as indicators of specific microbial groups. Total PLFAs were obtained by
 192 summing the contents of all fatty acids detected in each sample. The classification of the PLFAs are
 193 shown in Table 2.

194 The concentrations of soil organic carbon (SOC), total nitrogen (TN), and total phosphorus at the
 195 sites have been reported by Ai et al. (2017a). Soil pH and available phosphorus (SAP), ammonium N
 196 (NH₄), nitrate N (NO₃), water-soluble organic C (WSOC), water-soluble NH₄ (WNH₄), and
 197 water-soluble NO₃ (WNO₃) contents were measured as described by Ai et al (2017b). The soil moisture
 198 contents of sampling sites during investigation were determined gravimetrically by drying the samples
 199 to a constant weight at 105 °C, and then the water content was expressed as a percentage of the soil dry
 200 weight. The characteristics of the rhizospheric and non-rhizospheric soils are shown in Table 3.

201 **Table 3.** Characteristics of the rhizospheric and non-rhizospheric soils.

	Slope aspect	pH	Water Content (100%)	SOC (g kg ⁻¹)	SAP (mg kg ⁻¹)	NO ₃ (mg kg ⁻¹)	NH ₄ (mg kg ⁻¹)	WSOC (mg kg ⁻¹)	WNO ₃ (mg kg ⁻¹)	WNH ₄ (mg kg ⁻¹)
Rhizospheric soil	South-facing	8.55	7.73	9.20	3.23	8.60	12.94	59.12	1.55	0.61
	North-facing	8.72	10.37	7.36	2.41	9.70	9.87	37.02	1.27	0.44
	Northeast-facing	8.63	10.60	5.21	1.98	7.33	9.05	45.32	1.77	0.53
Non-rhizospheric soil	South-facing	8.54	8.13	5.53	1.35	4.93	12.32	38.14	1.20	0.50
	North-facing	8.58	10.31	4.90	1.37	6.73	13.13	36.47	0.98	0.38
	Northeast-facing	8.58	10.45	4.27	1.68	6.27	12.42	40.39	1.38	0.45

202 2.4 Calculations and statistical analysis

203 The metabolic quotient (10³ h⁻¹) was calculated as BR per unit MBC: metabolic
 204 quotient=10³×BR/MBC=10³×(mg kg⁻¹ h⁻¹)/(mg kg⁻¹) (Anderson and Domsch, 1993). RE was
 205 calculated as: RE=Rs/NRs, where Rs is a microbial property in RS, and NRs is a microbial property in
 206 NRS (Mukhopadhyay et al., 2016). For example, the RE for MBC: RE=RS MBC/NRS MBC=(mg
 207 kg⁻¹)/(mg kg⁻¹). All data were analysed using one-way ANOVAs, followed by Duncan's tests at a
 208 probability level of P<0.05 for multiple comparisons. All statistical analyses were performed using
 209 SPSS 20.0 (SPSS Inc., Chicago, USA), and structural equation models (SEMs) were analysed using the
 210 AMOS SPSS expansion pack. A redundancy analysis (RDA) was performed using CANOCO 5.0
 211 (Biometris, Wageningen, the Netherlands). The graphs were plotted using SigmaPlot 12.5 (Systat
 212 Software, San Jose, USA).

213 3 Results

214 3.1 Impacts of slope aspect on MBC content, respiration, and BR/MBC

215 RS MBC content did not differ significantly among the slope aspects, but NRS MBC content in the
 216 north-facing slope was higher than those in the south- and northeast-facing slopes (Fig. 1A). The RE
 217 for MBC in the south-facing slope was highest among the slope aspects (Fig. 2A). Slope aspect did not
 218 affect BR, BR/MBC, or SIR in either RS or NRS (Fig. 1B and Table 4). The RE for BR did not differ
 219 significantly among the slope aspects (Fig. 2A). The RE for SIR in the south-facing slope was higher
 220 than that in the north-facing slope.

221 **Table 4.** Microbial respiratory quotients (BR/MBC), ratios of fungal PLFA content to bacteria PLFA
 222 content (F/B), and ratios of G⁺ PLFA content to G⁻ PLFA content (G⁺/G⁻) in the rhizospheric and
 223 non-rhizospheric soils.

Slope aspect	Rhizospheric soil			Non-rhizospheric soil		
	BR/MBC (10 ³ h ⁻¹)	F/B ratio	G ⁺ /G ⁻ ratio	BR/MBC (10 ³ h ⁻¹)	F/B ratio	G ⁺ /G ⁻ ratio
South-facing	3.03±0.49a	0.07±0.00a	2.16±0.58a	2.47±0.52a	0.07±0.00a	1.45±0.23a
North-facing	2.67±0.41a	0.03±0.00b	1.55±0.29a	2.00±0.26a	0.04±0.00b	1.20±0.10a
Northeast-facing	2.77±0.23a	0.04±0.00b	1.54±0.16a	2.47±0.35a	0.05±0.00ab	1.33±0.06a

224 3.2 Impacts of slope aspect on microbial PLFA contents and composition

225 The microbial PLFA contents in RS differed significantly among the slope aspects. Total PLFA
 226 contents in the north- and northeast-facing slopes were 115 and 88% higher, respectively, than that in
 227 the south-facing slope (Fig. 3A). Fungal PLFA content did not differ significantly among the slope
 228 aspects (Fig. 3A). Bacterial PLFA content was similar to the trend for total PLFA content, with the
 229 lowest content in the south-facing slope (Fig. 3B). In contrast to total PLFA content, the ratio of fungal
 230 PLFA content to bacterial PLFA content (F/B ratio) in the south-facing slope was significantly higher
 231 than those in the north- and northeast-facing slopes (Table 4). Both G⁺ and G⁻ PLFA contents had
 232 trends similar to that of the bacterial PLFA content, with the lowest contents in the south-facing slope
 233 (Fig. 3B). The ratio of G⁺ PLFA content to G⁻ PLFA content (G⁺/G⁻ ratio) did not differ significantly
 234 among the slope aspects (Table 4). Actinomycete PLFA content in the north-facing slope was 102%
 235 higher than that in the south-facing slope, similar to that of G⁻ PLFA content (Fig. 3A).

236 The composition of the NRS PLFA contents also differed significantly among the slope aspects.
 237 Total PLFA content in the north-facing slope was 50 and 62% higher than those in the south- and
 238 northeast-facing slopes, respectively (Fig. 3C). Bacterial PLFA content had a trend similar to that of
 239 total PLFA content, with the highest content in the north-facing slope (Fig. 3D). Fungal PLFA content
 240 in the south- and north-facing slopes was significantly higher than that in the northeast-facing slope
 241 (Fig. 3C). The F/B ratio in the south-facing was substantially higher than that in the north-facing slope
 242 (Table 4). G⁻ PLFA content had a trend similar to that of bacterial PLFA content, and G⁺ PLFA content
 243 did not differ significantly among the slope aspects (Fig. 3D). The G⁺/G⁻ ratio did not differ
 244 significantly among the slope aspects (Table 4). Actinomycete PLFA content had a trend similar to that
 245 of fungal PLFA content, with higher contents in the south- and north-facing slopes, which were 149 and
 246 117% higher, respectively, than that in the northeast-facing slope (Fig. 3D).

247 The REs for total, bacterial, G⁺, G⁻, and actinomycete PLFA contents differed significantly among
 248 the slope aspects, but the RE for fungal PLFA content did not (Fig. 2B and C). The REs for total, G⁺, G⁻,
 249 bacterial, actinomycete PLFA contents in the northeast-facing slope were highest among the slope
 250 aspects.

251 3.3 Redundancy analysis (RDA)

252 The constrained RDAs indicated that environmental factors affected RS microbial characteristics (Fig.
 253 4A). The total variation was 6.10, and the explanatory variables accounted for 96.8%. The first two
 254 axes (RDA1 and RDA2) explained 89.6% of the total variance, wherein 84.1% was attributed to RDA1
 255 and 5.5% to RDA2. WSOC content was the most significant of the seven environmental factors and
 256 explained 63.6% ($P=0.006$) of the total variance. The slope aspect was the next most significant
 257 environmental variable and explained 62.8% ($P=0.004$), followed by NH₄ (58.6%, $P=0.004$), SAP

258 (45.7%, $P=0.022$), and WNH_4 (45.2%, $P=0.032$) contents.

259 The constrained RDAs indicated that environmental factors affected NRS microbial characteristics
260 (Fig. 4B). The total variation was 2.97, and the explanatory variables accounted for 94.2%. RDA1 and
261 RDA2 explained 81.6% of the total variance, 68.3% for RDA1 and 13.3% for RDA2. Among the seven
262 environmental factors, WNO_3 content was the most significant and explained 34.7% ($P=0.04$) of the
263 total variance.

264 3.4 Path analysis

265 The final SEM based on all indices adequately fitted the data to describe the effects of the
266 environmental factors on RS microbial characteristics ($\chi^2=0.506$; $P=0.918$; RMSEA, $P<0.001$; Fig. 5A).
267 The final model accounted for 99% of the variation in RS WSOC content, with 71% of the variation in
268 bacterial PLFA content, 78% of the variation in G^+ PLFA content, and 72% of the variation in total
269 PLFA content. Slope aspect was positively correlated with WSOC content ($P<0.001$). WSOC content
270 was negatively correlated with bacterial PLFA ($P<0.001$), G^+ PLFA ($P<0.001$), and total PLFA
271 ($P<0.001$) contents.

272 All indices adequately fitted the data to describe the effects of the environmental factors on NRS
273 microbial characteristics ($\chi^2=3.222$; $P=0.521$; RMSEA, $P<0.001$; Fig. 5B). The model was able to
274 explain 59% of the variation in WNH_4 content, 58% of the variation in MBC content, 55% of the
275 variation in G^- PLFA content, and 45% of variation in total PLFA content. Slope aspect was strongly
276 positively correlated with WNH_4 content ($P<0.001$). WNH_4 content was strongly negatively correlated
277 with MBC ($P<0.001$), G^- PLFA ($P<0.05$), and total PLFA ($P<0.05$) contents.

278 4 Discussion

279 4.1 MBC, respiration, and BR/MBC

280 Soil microbial biomass is closely associated with soil-moisture content (Zhang et al., 2005; Drenovsky
281 et al., 2010; Ma et al., 2015). The north-facing slope contained more moisture than the south-facing
282 slope (Sariyildiz et al., 2005), so microbial activity in the north-facing slope was higher than that in the
283 south-facing slope. NRS MBC content in the north-facing slope was significantly higher than that in
284 the south-facing slope in our study, supporting our hypothesis 1 and in agreement with other studies
285 (Huang et al., 2015; Sidari et al., 2008). Carletti et al. (2009), however, reported an opposite trend: soil
286 MBC content was higher in a south-facing slope. This disparity may have been due to the differences in
287 plant species, soil type, and regional climate (Gilliam et al., 2014). NRS MBC content in the
288 northeast-facing slope was lower than that in the north-facing slope, inconsistent with Huang et al.
289 (2015), whose study area had the same soil and climatic conditions as ours. The different result may
290 mainly be due to the different plant species: the effect of shrubland plants (Huang et al., 2015) on NRS
291 may be different from the effect of grassland plants (our study). Plant shade can affect soil microbial
292 activity (Blok et al., 2010), so different shading can lead to different MBC contents.

293 Plant roots release a high amount of exudates, such as sugars, amino acids, organic acids,
294 hormones, and enzymes (Zhang et al., 2012; Grayston et al., 1997). In contrast, soil with a low amount
295 of shading is prone to desiccation (Wang et al., 2008), and the quantity of exudates released by plant
296 roots is low, which may lead to lower activities of the microorganisms. RS MBC content therefore
297 should be higher than NRS MBC content, consistent with our results. In our study, the RE for MBC
298 content in the south-facing slope was significantly higher than that in the north-facing slope. The light

299 in south-facing slopes would have a greater impact on the soil micro-environmental than that in
300 north-facing slopes, because south-facing slopes in the Northern Hemisphere receive more sunlight
301 than north-facing slopes, leading to a larger difference between RS and NRS in south-facing slopes.
302 The RDA and path analysis found that NRS WSOC, WNO₃, and WNH₄ contents were well correlated
303 with MBC content (Figs. 4B and 5B), supporting our hypothesis that soil C and N the main soil
304 nutrient factors that affect RS and NRS microbial communities, and in agreement with other studies
305 (Haynes, 2000; Huang et al., 2014).

306 Neither RS nor NRS BR, SIR, and BR/MBC differed significantly among the slope aspects,
307 indicating that the actual microbial activities, potential microbial activities, and bioenergetic status of
308 the microbial biomass (Nannipieri et al., 1990; Wardle, 1995; Sinha et al., 2009) were similar among
309 the slope aspects in the study area. The RE of SIR in the south-facing slope was 96% higher than that
310 in the north-facing slope, indicating that the effect of slope aspect on the RS and NRS SIRs was more
311 evident in the south-facing slope than that in the north-facing slope, even though the influence of slope
312 aspect on SIR was not significant either in RS or NRS.

313 4.2 PLFA contents and composition

314 4.2.1 Fungal and bacterial PLFA contents and composition

315 NRS fungal PLFA content in the northeast-facing slope was lower than those in the south- and
316 north-facing slopes, but RS fungal PLFA content did not differ significantly among the slope aspects.
317 Previous studies have reported different results: Huang et al. (2015) and Gilliam et al. (2014) found that
318 slope aspect significantly affected the fungal community, and fungal abundance was lower in
319 north-facing slope; Bardelli et al. (2017) found that fungal abundance did not differ significantly
320 between north- and south-facing slopes. These different results may be due to the differences in plant
321 species (e.g. herbs vs shrubs), soil conditions, climate, and research methods (Gilliam et al., 2014). The
322 different responses of RS and NRS fungal PLFA contents indicated that rhizospheres could form an
323 environment that negates the effect of slope aspect on fungal communities more than non-rhizospheric
324 zones. SOC and TN can supply the microbial biomass with enough C, N, and energy resources to
325 support microbial growth (Jia et al., 2005), so the solubility of SOC (WSOC) and nitrogen (WNO₃,
326 WNH₄) would be closely associated with the fungal community. The RDA found that NRS WSOC and
327 WNO₃ were well correlated with fungal PLFA content (Fig. 4B), supporting our hypothesis 2 and
328 agreeing with previous studies (Haynes, 2000; Nilsson et al., 2005; Huang et al., 2014).

329 The effect of slope aspect on PLFA content differed between bacteria and fungi. Both RS and NRS
330 bacterial PLFA contents in the south-facing slope were lower than those in the north-facing slope,
331 suggesting more soil moisture in the north-facing slope suitable for the growth of bacteria, in
332 agreement with some studies (Huang et al., 2015; Ascher et al., 2012) but not others (Gilliam et al.,
333 2014; Bardelli et al., 2017). The effect of slope aspect on the bacterial community would therefore
334 become significant due to the plant species, soil type, and climatic conditions. The RE for bacterial
335 PLFA content in the northeast-facing slope was significantly higher than that in the south-facing slope,
336 indicating that the environmental conditions of the rhizosphere helped the bacterial community to resist
337 environmental pressure. The RDA indicated that the RS WNH₄, WSOC, and SAP contents were well
338 correlated with the bacterial PLFA content, and the NRS WNH₄ content was well correlated with the
339 bacterial PLFA content (Fig. 4A, B). The path analysis indicated that RS WSOC content was the main
340 factor influencing the bacterial PLFA content and mainly affected the G⁺ PLFA content (Fig. 5A), in
341 agreement with another study (Fierer et al., 2003), but the NRS WNH₄ content mainly affected the G⁻

342 PLFA content (Fig. 5B). These results indicated that the RS and NRS bacterial PLFA contents were
343 affected by different soil nutrient factors.

344 Soil moisture is an important environmental factor affecting the composition of microbial
345 communities, the higher amounts of soil moisture in north-facing slopes (Sariyildiz et al., 2005) can
346 lead to lower F/B ratios (Brockett et al., 2012; Drenovsky et al., 2010; Ma et al., 2015). The F/B ratio
347 in our study was highest in the south-facing slope and lowest in the north-facing slope for both RS and
348 NRS, consistent with previous studies (Huang et al., 2015; Gilliam et al., 2014). The higher amount of
349 soil moisture in the north-facing slope would reduce soil aeration, and lower oxygen levels would
350 create an environment favourable for facultative and obligate anaerobic bacteria (Drenovsky et al.,
351 2004). Drought stress in the south-facing slope would likely facilitate the survival of fungi, because soil
352 fungi rely on more aerobic conditions and are more tolerant of drought due to their filamentous nature
353 (Zhang et al., 2005). The significant difference in the RE for bacterial PLFA content was not obvious
354 for fungal PLFA content, so the RE was much weaker in the fungal than the bacterial community,
355 consistent with Buyer et al. (2002). These results indicated that RE had a large effect on the structures
356 of the fungal and bacterial communities.

357 Previous studies have found that wetter soils are more enriched in G^+ bacteria (Zhang et al., 2005;
358 Drenovsky et al., 2010; Ma et al., 2015), in agreement with the result of the RE G^+ PLFA content, but
359 not the NRE G^+ PLFA content. As RE was significantly affected by slope aspect for the G^+ PLFA
360 content, this may be one of the reasons that caused the difference between RE and NRE G^+ PLFA
361 contents. Furthermore, the RDA indicated that the RS WSOC was well correlated with the RE G^+
362 PLFA content, and the NRS W_{NH_4} content was well correlated with the NRE G^+ PLFA content (Fig.
363 4A, B). Although drier soils tend to be more enriched in G^- bacteria (Zhang et al., 2005; Drenovsky et
364 al., 2010; Ma et al., 2015), both the higher RE and NRE G^- PLFA contents were recorded at the
365 north-facing slope. It has been shown that drier soils can lead to low root exudates, which may lead to
366 lower activities of the soil microorganisms (Zhang et al., 2015). The G^+/G^- ratio can indicate the
367 dominance of bacteria in soil microbial communities (Tscherko et al., 2004; Zhang et al., 2015).
368 Neither the RS nor the NRS G^+/G^- ratio was affected by slope aspect, indicating that slope aspect did
369 not significantly affect the dominant bacterial community in either RS or NRS.

370 4.2.2 Actinomycete and total PLFA contents

371 RS and NRS actinomycete PLFA contents were significantly affected by slope aspect, supporting our
372 hypothesis 1. Actinomycetes and G^+ bacteria have similar life habits, so wetter soils are more enriched
373 in actinomycetes (Zhang et al., 2005; Drenovsky et al., 2010; Ma et al., 2015). RS actinomycete PLFA
374 content in the north-facing slope was therefore higher than that in the south-facing slope, and the
375 northeast-facing slope had more moderate growth conditions for actinomycetes compared with the
376 north-facing and south-facing slopes. NRS actinomycete PLFA content, however, was lower in the
377 northeast-facing slope than those in the north-facing and south-facing slopes. This difference may have
378 been due to RE, because RE in the northeast-facing slope was significantly higher than those in the
379 other slopes. RE will affect soil nutrients more in RS than NRS (Zhang et al., 2012; Grayston et al.,
380 1997). The RDA indicated that the RS but not NRS actinomycete PLFA content was well correlated
381 with WSOC and W_{NH_4} contents, supporting our hypothesis 2 (Fig. 4A, B).

382 The G^+ and actinomycete PLFA contents accounted for more than 50% of total PLFA content in
383 both RS (57–59%) and NRS (54–58%), so the distribution of total PLFA content in our study area
384 depended mainly on the G^+ and actinomycete PLFA contents. Wetter soils tend to be more enriched in

385 G⁺ bacteria and actinomycetes (Zhang et al., 2005; Drenovsky et al., 2010; Ma et al., 2015), so total
386 PLFA contents in both RS and NRS were highest in the north-facing slope. Total PLFA content,
387 however, was higher in the northeast-facing slope than that in the south-facing slope for RS and did not
388 differ significantly between the northeast-facing and south-facing slopes in NRS. These differences in
389 total PLFA content between RS and NRS may have been mostly due to RE. The shading by herbs in the
390 northeast-facing slope may make RS as suitable for microbial life as in the north-facing slope, whereas
391 NRS in the northeast-facing slope was not suitable for microbial life as in the south-facing slope
392 without plant shading. The path analysis indicated that WSOC content had a significant effect on RS
393 total PLFA content and that WNH₄ content had a significant effect on NRS total PLFA content (Fig. 5A,
394 B), as expected (Haynes, 2000; Huang et al., 2014; Nilsson et al., 2005). These results supported our
395 hypotheses 1 and 2, but hypothesis 1 was inconsistent with the study by Huang et al. (2015) who found
396 a significantly higher total PLFA content in a south-facing slope than in other slopes. RE may have
397 been one of the main reasons, because shrub shading (Huang et al., 2015) clearly differs from herb
398 shading (our study), which could be caused by a different RE (Blok et al., 2010).

399 5 Conclusions

400 This study provides experimental evidence that slope aspect can markedly but differentially affect
401 MBC and PLFA contents in RS and NRS that and the different influences can produce an evident RE;
402 the RE for most microbial properties was higher in the northeast-facing slope. WSOC content was well
403 correlated with RS microbial properties, and WNH₄ content was well correlated with NRS microbial
404 properties, likely due to RE. Studies of the influence of slope aspect on soil microbial communities
405 should therefore consider REs. This study provides new insights into the influences of topographic
406 factors affecting the mechanisms driving the structure of microbial communities in a
407 micro-ecosystemic environment. Further field investigation on different plant species, however, is
408 needed to determine the role of RE under the effect of slope aspect in micro-ecosystemic environments.

409 Author contributions

410 GbL and SX provided research ideas and designed the experiments. They were also responsible for the
411 revision of the paper. SX, ZmA, JyZ, and HfL participated in the collection of soil samples, and ZmA,
412 JyZ, and HfL contributed to the soil analysis. ZmA analyzed the data and wrote the paper.

413
414 *Acknowledgements.* We thank the National Natural Science Foundation of China (41371510, 41671513,
415 41471438) and the West Young Scholars Project of The Chinese Academy of Sciences (XAB2015A05)
416 for funding this work.

417 References

- 418 Ai, Z. M., He, L. R., Xin, Q., Yang, T., Liu, G. B., and Xue, S.: Slope aspect affects the non-structural
419 carbohydrates and C: N: P stoichiometry of *Artemisia sacrorum* on the Loess Plateau in China,
420 *Catena*, 152, 9-17, doi:10.1016/j.catena.2016.12.024, 2017a.
- 421 Ai, Z. M., Zhang, J. Y., Liu, H. F., Xin, Q., Xue, S., and Liu, G. B.: Soil nutrients influence the
422 photosynthesis and biomass in invasive *Panicum virgatum* on the Loess Plateau in China,

423 Plant Soil, 418, 153-164, [doi:10.1007/s11104-017-3286-x](https://doi.org/10.1007/s11104-017-3286-x), 2017b.

424 Anderson, T.-H., and Domsch, K.: The metabolic quotient for CO₂ (qCO₂) as a specific activity
425 parameter to assess the effects of environmental conditions, such as pH, on the microbial
426 biomass of forest soils, *Soil Biol. Biochem.*, 25, 393-395, [doi:10.1016/0038-0717\(93\)90140-7](https://doi.org/10.1016/0038-0717(93)90140-7),
427 1993.

428 Ascher, J., Sartori, G., Graefe, U., Thornton, B., Ceccherini, M., Pietramellara, G., and Egli, M.: Are
429 humus forms, mesofauna and microflora in subalpine forest soils sensitive to thermal
430 conditions?, *Biol. Fertility Soils*, 48, 709-725, [doi:10.1007/s00374-012-0670-9](https://doi.org/10.1007/s00374-012-0670-9), 2012.

431 Bååth, E., and Anderson, T.-H.: Comparison of soil fungal/bacterial ratios in a pH gradient using
432 physiological and PLFA-based techniques, *Soil Biol. Biochem.*, 35, 955-963,
433 [doi:10.1016/S0038-0717\(03\)00154-8](https://doi.org/10.1016/S0038-0717(03)00154-8), 2003.

434 Bardelli, T., Gómez-Brandón, M., Ascher-Jenull, J., Fornasier, F., Arfaioli, P., Francioli, D., Egli, M.,
435 Sartori, G., Insam, H., and Pietramellara, G.: Effects of slope exposure on soil
436 physico-chemical and microbiological properties along an altitudinal climosequence in the
437 Italian Alps, *Sci. Total Environ.*, 575, 1041-1055, [doi:10.1016/j.scitotenv.2016.09.176](https://doi.org/10.1016/j.scitotenv.2016.09.176), 2017.

438 Bardgett, R. D., Hobbs, P. J., and Frostegård, Å.: Changes in soil fungal: bacterial biomass ratios
439 following reductions in the intensity of management of an upland grassland, *Biol. Fertility
440 Soils*, 22, 261-264, [doi:10.1007/BF00382522](https://doi.org/10.1007/BF00382522), 1996.

441 Bennie, J., Huntley, B., Wiltshire, A., Hill, M. O., and Baxter, R.: Slope, aspect and climate: Spatially
442 explicit and implicit models of topographic microclimate in chalk grassland, *Ecol. Model.*,
443 216, 47-59, [doi:10.1016/j.ecolmodel.2008.04.010](https://doi.org/10.1016/j.ecolmodel.2008.04.010), 2008.

444 Bligh, E. G., and Dyer, W. J.: A rapid method of total lipid extraction and purification, *Canadian
445 journal of biochemistry and physiology*, 37, 911-917, [doi:10.1139/y59-099](https://doi.org/10.1139/y59-099), 1959.

446 Blok, D., Heijmans, M. M., [Schaepman - strub](https://doi.org/10.1016/j.glochange.2010.02.001), G., Kononov, A., Maximov, T., and Berendse, F.:
447 Shrub expansion may reduce summer permafrost thaw in Siberian tundra, *Global Change
448 Biol.*, 16, 1296-1305, [doi:10.1111/j.1365-2486.2009.02110.x](https://doi.org/10.1111/j.1365-2486.2009.02110.x), 2010.

449 Brockett, B. F. T., Prescott, C. E., and Grayston, S. J.: Soil moisture is the major factor influencing
450 microbial community structure and enzyme activities across seven biogeoclimatic zones in
451 western Canada, *Soil Biol. Biochem.*, 44, 9-20, [doi:10.1016/j.soilbio.2011.09.003](https://doi.org/10.1016/j.soilbio.2011.09.003), 2012.

452 Buyer, J. S., Roberts, D. P., and Russek-Cohen, E.: Soil and plant effects on microbial community
453 structure, *Can. J. Microbiol.*, 48, 955-964, [doi:10.1139/W02-095](https://doi.org/10.1139/W02-095), 2002.

454 Carletti, P., Vendramin, E., Pizzeghello, D., Concheri, G., Zanella, A., Nardi, S., and Squartini, A.: Soil
455 humic compounds and microbial communities in six spruce forests as function of parent
456 material, slope aspect and stand age, *Plant Soil*, 315, 47-65, [doi:10.1007/s11104-008-9732-z](https://doi.org/10.1007/s11104-008-9732-z),
457 2009.

458 Chen, C., Condrón, L., Davis, M., and Sherlock, R.: Phosphorus dynamics in the rhizosphere of
459 perennial ryegrass (*Lolium perenne* L.) and radiata pine (*Pinus radiata* D. Don.), *Soil Biol.
460 Biochem.*, 34, 487-499, [doi:10.1016/S0038-0717\(01\)00207-3](https://doi.org/10.1016/S0038-0717(01)00207-3), 2002.

461 Dearborn, K. D., and Danby, R. K.: Aspect and slope influence plant community composition more
462 than elevation across forest-tundra ecotones in subarctic Canada, *Journal of Vegetation
463 Science*, 28, 595-604, [doi:10.1111/jvs.12521](https://doi.org/10.1111/jvs.12521), 2017.

464 Drenovsky, R., Vo, D., Graham, K., and Scow, K.: Soil water content and organic carbon availability
465 are major determinants of soil microbial community composition, *Microb. Ecol.*, 48, 424-430,
466 [doi:10.1007/s00248-003-1063-2](https://doi.org/10.1007/s00248-003-1063-2), 2004.

467 Drenovsky, R. E., Steenwerth, K. L., Jackson, L. E., and Scow, K. M.: Land use and climatic factors
468 structure regional patterns in soil microbial communities, *Global Ecol. Biogeogr.*, 19, 27-39,
469 [doi:10.1111 / j.1466-8238.2009.00486.x](https://doi.org/10.1111/j.1466-8238.2009.00486.x), 2010.

470 Fierer, N., Schimel, J. P., and Holden, P. A.: Variations in microbial community composition through
471 two soil depth profiles, *Soil Biol. Biochem.*, 35, 167-176,
472 [doi:10.1016/S0038-0717\(02\)00251-1](https://doi.org/10.1016/S0038-0717(02)00251-1), 2003.

473 Frostegård, Å., Tunlid, A., and Bååth, E.: Phospholipid fatty acid composition, biomass, and activity of
474 microbial communities from two soil types experimentally exposed to different heavy metals,
475 *Appl. Environ. Microbiol.*, 59, 3605-3617, [doi:0099-2240/93/113605-13\\$02.00/0](https://doi.org/10.1128/aem.59.11.3605-3617.1993), 1993.

476 Gilliam, F. S., Håll, R., Chudomelov, M., McCulley, R. L., and Nelson, J. A.: Variation in vegetation
477 and microbial linkages with slope aspect in a montane temperate hardwood forest, *Ecosphere*,
478 5, 1-17, [doi:10.1890 / ES13-00379.1](https://doi.org/10.1890/ES13-00379.1), 2014.

479 Grayston, S., Vaughan, D., and Jones, D.: Rhizosphere carbon flow in trees, in comparison with annual
480 plants: the importance of root exudation and its impact on microbial activity and nutrient
481 availability, *Appl Soil Ecol*, 5, 29-56, [doi:10.1016/S0929-1393\(96\)00126-6](https://doi.org/10.1016/S0929-1393(96)00126-6), 1997.

482 Griffiths, B. S., Bonkowski, M., Dobson, G., and Caul, S.: Changes in soil microbial community
483 structure in the presence of microbial-feeding nematodes and protozoa, *Pedobiologia*, 43,
484 297-304, 1999.

485 Harris, J.: Soil microbial communities and restoration ecology: facilitators or followers?, *Science*, 325,
486 573-574, [doi:10.1126/science.1172975](https://doi.org/10.1126/science.1172975), 2009.

487 Haynes, R.: Labile organic matter as an indicator of organic matter quality in arable and pastoral soils
488 in New Zealand, *Soil Biol. Biochem.*, 32, 211-219, [doi:10.1016/S0038-0717\(99\)00148-0](https://doi.org/10.1016/S0038-0717(99)00148-0),
489 2000.

490 Hinsinger, P., Bengough, A. G., Vetterlein, D., and Young, I. M.: Rhizosphere: biophysics,
491 biogeochemistry and ecological relevance, *Plant Soil*, 321, 117-152,
492 [doi:10.1007/s11104-008-9885-9](https://doi.org/10.1007/s11104-008-9885-9), 2009.

493 Huang, X., Liu, S., Wang, H., Hu, Z., Li, Z., and You, Y.: Changes of soil microbial biomass carbon
494 and community composition through mixing nitrogen-fixing species with *Eucalyptus*
495 *urophylla* in subtropical China, *Soil Biol. Biochem.*, 73, 42-48,
496 [doi:10.1016/j.soilbio.2014.01.021](https://doi.org/10.1016/j.soilbio.2014.01.021), 2014.

497 Huang, Y.-M., Liu, D., and An, S.-S.: Effects of slope aspect on soil nitrogen and microbial properties
498 in the Chinese Loess region, *Catena*, 125, 135-145, [doi:10.1016/j.catena.2014.09.010](https://doi.org/10.1016/j.catena.2014.09.010), 2015.

499 Hueso, S., Hernández, T., and García, C.: Resistance and resilience of the soil microbial biomass to
500 severe drought in semiarid soils: The importance of organic amendments, *Appl Soil Ecol*, 50,
501 27-36, [doi:10.1016/j.apsoil.2011.07.014](https://doi.org/10.1016/j.apsoil.2011.07.014), 2011.

502 Jia, G. M., Cao, J., Wang, C. Y., and Wang, G.: Microbial biomass and nutrients in soil at the different
503 stages of secondary forest succession in Ziwulin, northwest China, *For. Ecol. Manage.*, 217,
504 117-125, [doi:10.1016/j.foreco.2005.05.055](https://doi.org/10.1016/j.foreco.2005.05.055), 2005.

505 Kramer, C., and Gleixner, G.: Variable use of plant-and soil-derived carbon by microorganisms in
506 agricultural soils, *Soil Biol. Biochem.*, 38, 3267-3278, [doi:10.1016/j.soilbio.2006.04.006](https://doi.org/10.1016/j.soilbio.2006.04.006),
507 2006.

508 Liu, M., Zheng, R., Bai, S., and Wang, J.: Slope aspect influences arbuscular mycorrhizal fungus
509 communities in arid ecosystems of the Daqingshan Mountains, Inner Mongolia, North China,
510 *Mycorrhiza*, 27, 189-200, [doi:10.1007/s00572-016-0739-7](https://doi.org/10.1007/s00572-016-0739-7), 2017.

511 Ma, L. N., Guo, C. Y., Lü X. T., Yuan, S., and Wang, R. Z.: Soil moisture and land use are major
512 determinants of soil microbial community composition and biomass at a regional scale in
513 northeastern China, *Biogeosciences*, 12, 2585-2596, [doi:10.5194/bg-12-2585-2015](https://doi.org/10.5194/bg-12-2585-2015), 2015.

514 Marschner, P., Marino, W., and Lieberei, R.: Seasonal effects on microorganisms in the rhizosphere of
515 two tropical plants in a polyculture agroforestry system in Central Amazonia, Brazil, *Biol.*
516 *Fertility Soils*, 35, 68-71, [doi:10.1007/s00374-001-0435-3](https://doi.org/10.1007/s00374-001-0435-3), 2002.

517 Mukhopadhyay, S., Masto, R. E., Cerdà A., and Ram, L. C.: Rhizosphere soil indicators for carbon
518 sequestration in a reclaimed coal mine spoil, *Catena*, 141, 100-108,
519 [doi:10.1016/j.catena.2016.02.023](https://doi.org/10.1016/j.catena.2016.02.023), 2016.

520 Nannipieri, P., Grego, S., and Ceccanti, B.: Ecological significance of the biological activity in soil,
521 *Soil Biochemistry*, 6, 293-355, [doi:10.1201/9780203739389-7](https://doi.org/10.1201/9780203739389-7), 1990.

522 Nilsson, L. O., Giesler, R., Bååth, E., and Wallander, H.: Growth and biomass of mycorrhizal mycelia
523 in coniferous forests along short natural nutrient gradients, *New Phytol.*, 165, 613-622,
524 [doi:10.1111/j.1469-8137.2004.01223.x](https://doi.org/10.1111/j.1469-8137.2004.01223.x), 2005.

525 Qin, Y. Y., Feng, Q., Holden, N. M., and Cao, J. J.: Variation in soil organic carbon by slope aspect in
526 the middle of the Qilian Mountains in the upper Heihe River Basin, China, *Catena*, 147,
527 308-314, [doi:10.1016/j.catena.2016.07.025](https://doi.org/10.1016/j.catena.2016.07.025), 2016.

528 Sariyildiz, T., Anderson, J., and Kucuk, M.: Effects of tree species and topography on soil chemistry,
529 litter quality, and decomposition in Northeast Turkey, *Soil Biol. Biochem.*, 37, 1695-1706,
530 [doi:10.1016/j.soilbio.2005.02.004](https://doi.org/10.1016/j.soilbio.2005.02.004), 2005.

531 Selvakumar, G., Joshi, P., Mishra, P. K., Bisht, J. K., and Gupta, H. S.: Mountain aspect influences the
532 genetic clustering of psychrotolerant phosphate solubilizing Pseudomonads in the Uttarakhand
533 Himalayas, *Curr. Microbiol.*, 59, 432-438, [doi:10.1007/s00284-009-9456-1](https://doi.org/10.1007/s00284-009-9456-1), 2009.

534 Sidari, M., Ronzello, G., Vecchio, G., and Muscolo, A.: Influence of slope aspects on soil chemical and
535 biochemical properties in a *Pinus laricio* forest ecosystem of Aspromonte (Southern Italy), *Eur*
536 *J Soil Biol*, 44, 364-372, [doi:10.1016/j.ejsobi.2008.05.001](https://doi.org/10.1016/j.ejsobi.2008.05.001), 2008.

537 Sinha, S., Masto, R., Ram, L., Selvi, V., Srivastava, N., Tripathi, R., and George, J.: Rhizosphere soil
538 microbial index of tree species in a coal mining ecosystem, *Soil Biol. Biochem.*, 41,
539 1824-1832, [doi:10.1016/j.soilbio.2008.11.022](https://doi.org/10.1016/j.soilbio.2008.11.022), 2009.

540 Tschirko, D., Hammesfahr, U., Marx, M.-C., and Kandeler, E.: Shifts in rhizosphere microbial
541 communities and enzyme activity of *Poa alpina* across an alpine chronosequence, *Soil Biol.*
542 *Biochem.*, 36, 1685-1698, [doi:10.1016/j.soilbio.2004.07.004](https://doi.org/10.1016/j.soilbio.2004.07.004), 2004.

543 Vance, E. D., Brookes, P. C., and Jenkinson, D. S.: An extraction method for measuring soil microbial
544 biomass C, *Soil Biol. Biochem.*, 19, 703-707, [doi:10.1016/0038-0717\(87\)90052-6](https://doi.org/10.1016/0038-0717(87)90052-6), 1987.

545 Wang, G. L., and Liu, G. B.: Study on the interspecific association of the *artemisia sacrorum*
546 community in Loess Hilly Region, Grassland of China,
547 [doi:10.3969/j.issn.1673-5021.2002.03.001](https://doi.org/10.3969/j.issn.1673-5021.2002.03.001), 2002.

548 Wang, L., Wang, Q., Wei, S., Shao, M. a., and Li, Y.: Soil desiccation for Loess soils on natural and
549 regrown areas, *For. Ecol. Manage.*, 255, 2467-2477, [doi:10.1016/j.foreco.2008.01.006](https://doi.org/10.1016/j.foreco.2008.01.006), 2008.

550 Wardle, D. A.: Impacts of disturbance on detritus food webs in agro-ecosystems of contrasting tillage
551 and weed management practices, *Adv. Ecol. Res.*, 26, 105-185,
552 [doi:10.1016/S0065-2504\(08\)60065-3](https://doi.org/10.1016/S0065-2504(08)60065-3), 1995.

553 Warembourg, F., Roumet, C., and Lafont, F.: Differences in rhizosphere carbon-partitioning among
554 plant species of different families, *Plant Soil*, 256, 347-357, [doi:10.1023/A:1026147622800](https://doi.org/10.1023/A:1026147622800),

555 2003.

556 Zelles, L.: Fatty acid patterns of phospholipids and lipopolysaccharides in the characterisation of
557 microbial communities in soil: a review, *Biol. Fertility Soils*, 29, 111-129,
558 [doi:10.1007/s003740050533](https://doi.org/10.1007/s003740050533), 1999.

559 Zhang, C., Liu, G. B., Xue, S., and Zhang, C. S.: Rhizosphere soil microbial properties on abandoned
560 croplands in the Loess Plateau, China during vegetation succession, *Eur J Soil Biol*, 50,
561 127-136, [doi:10.1016/j.ejsobi.2012.01.002](https://doi.org/10.1016/j.ejsobi.2012.01.002), 2012.

562 Zhang, C., Liu, G. B., Xue, S., and Wang, G. L.: Changes in rhizospheric microbial community
563 structure and function during the natural recovery of abandoned cropland on the Loess Plateau,
564 China, *Ecol. Eng.*, 75, 161-171, [doi:10.1016/j.ecoleng.2014.11.059](https://doi.org/10.1016/j.ecoleng.2014.11.059), 2015.

565 Zhang, W., Parker, K., Luo, Y., Wan, S., Wallace, L., and Hu, S.: Soil microbial responses to
566 experimental warming and clipping in a tallgrass prairie, *Global Change Biol.*, 11, 266-277,
567 [doi:10.1111/j.1365-2486.2005.00902.x](https://doi.org/10.1111/j.1365-2486.2005.00902.x), 2005.

568

569

570

571

572

573

574

575

576

577

578

579

580

581

582

583

584

585

586

587

588

589

590

591

592

593

594

595

596

597

598

599
 600
 601
 602
 603
 604
 605
 606
 607
 608
 609
 610
 611
 612
 613
 614
 615
 616
 617
 618
 619
 620
 621
 622
 623
 624
 625
 626
 627
 628
 629
 630
 631
 632
 633
 634
 635
 636
 637
 638
 639
 640
 641
 642

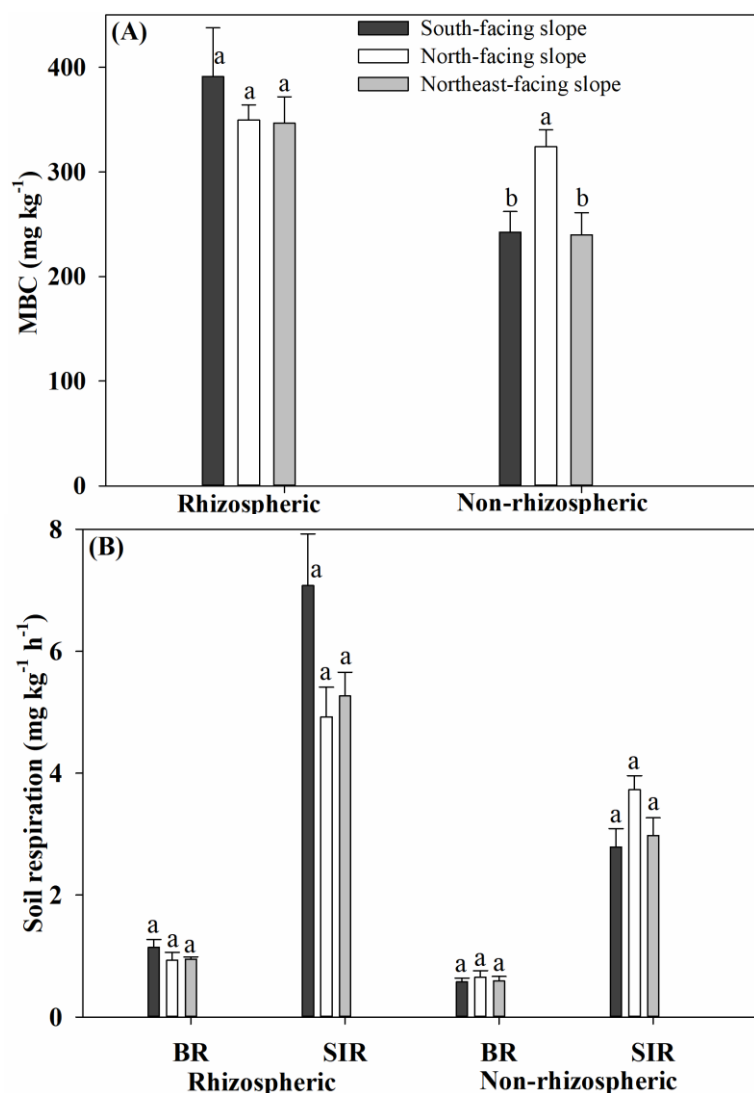

Fig. 1 Microbial biomass carbon (MBC) content, basal respiration (BR), and substrate-induced respiration (SIR) in the rhizospheric and non-rhizospheric soils. Error bars are standard errors (n=3). Different letters above the bars indicate significant differences at $P=0.05$.

643
 644
 645
 646
 647
 648
 649
 650
 651
 652
 653
 654
 655
 656
 657
 658
 659
 660
 661
 662
 663
 664
 665
 666
 667
 668
 669
 670
 671
 672
 673
 674
 675
 676
 677
 678
 679
 680
 681
 682
 683
 684
 685
 686

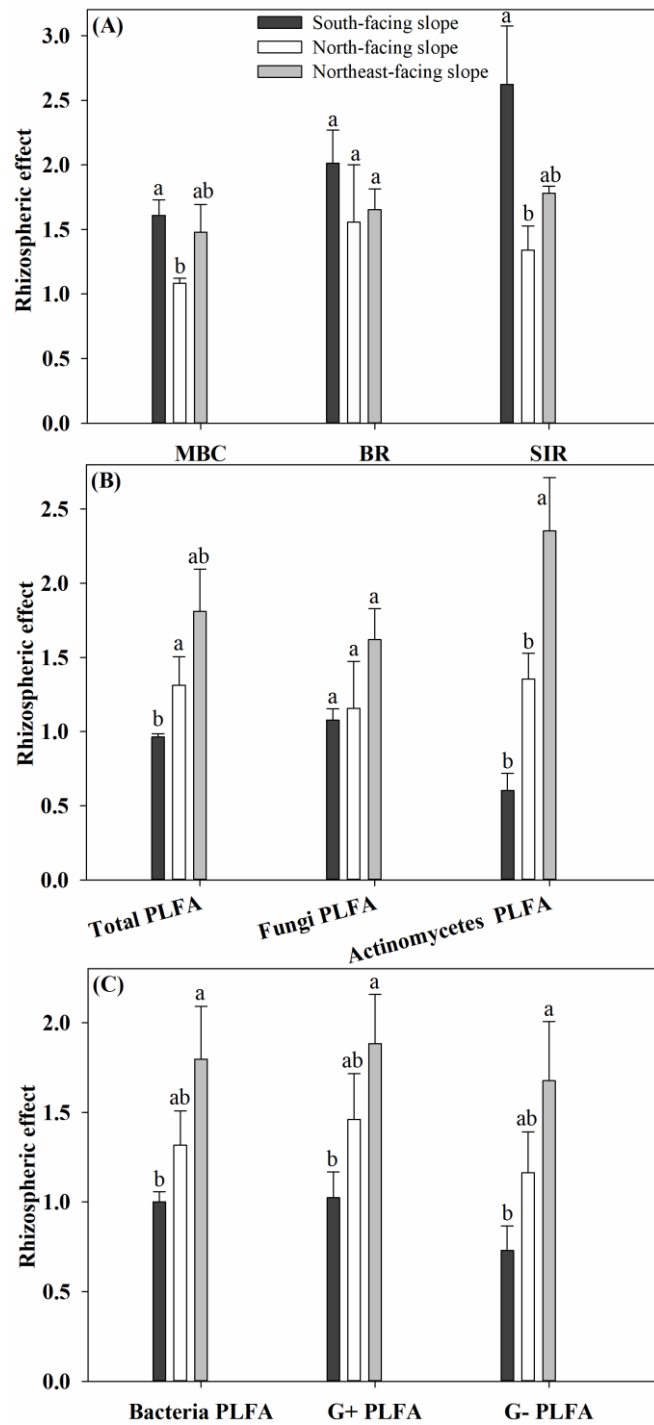

Fig. 2 The rhizospheric effects of MBC, BR, SIR, and PLFA contents. Error bars are standard errors (n=3). Different letters above the bars indicate significant differences at $P=0.05$.

687
 688
 689
 690
 691
 692
 693
 694
 695
 696
 697
 698
 699
 700
 701
 702
 703
 704
 705
 706
 707
 708
 709
 710
 711
 712
 713
 714
 715
 716
 717
 718
 719
 720
 721
 722
 723
 724
 725
 726
 727
 728
 729
 730

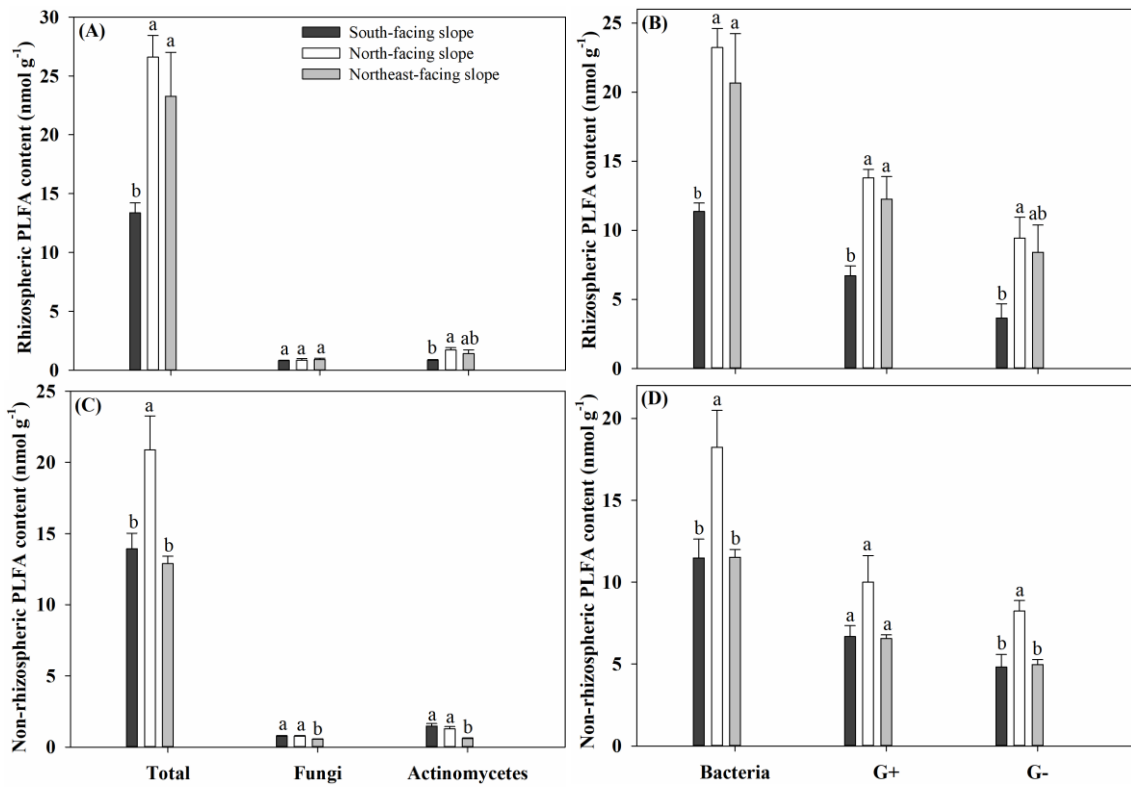

Fig. 3 Effects of slope aspect on PLFA contents in rhizospheric and non-rhizospheric soils. Error bars are standard errors (n=3). Different letters above the bars indicate significant differences at $P=0.05$.

731
 732
 733
 734
 735
 736
 737
 738
 739
 740
 741
 742
 743
 744
 745
 746
 747
 748
 749
 750
 751
 752
 753
 754
 755
 756
 757
 758
 759
 760
 761
 762
 763
 764
 765
 766
 767
 768
 769
 770
 771
 772
 773
 774

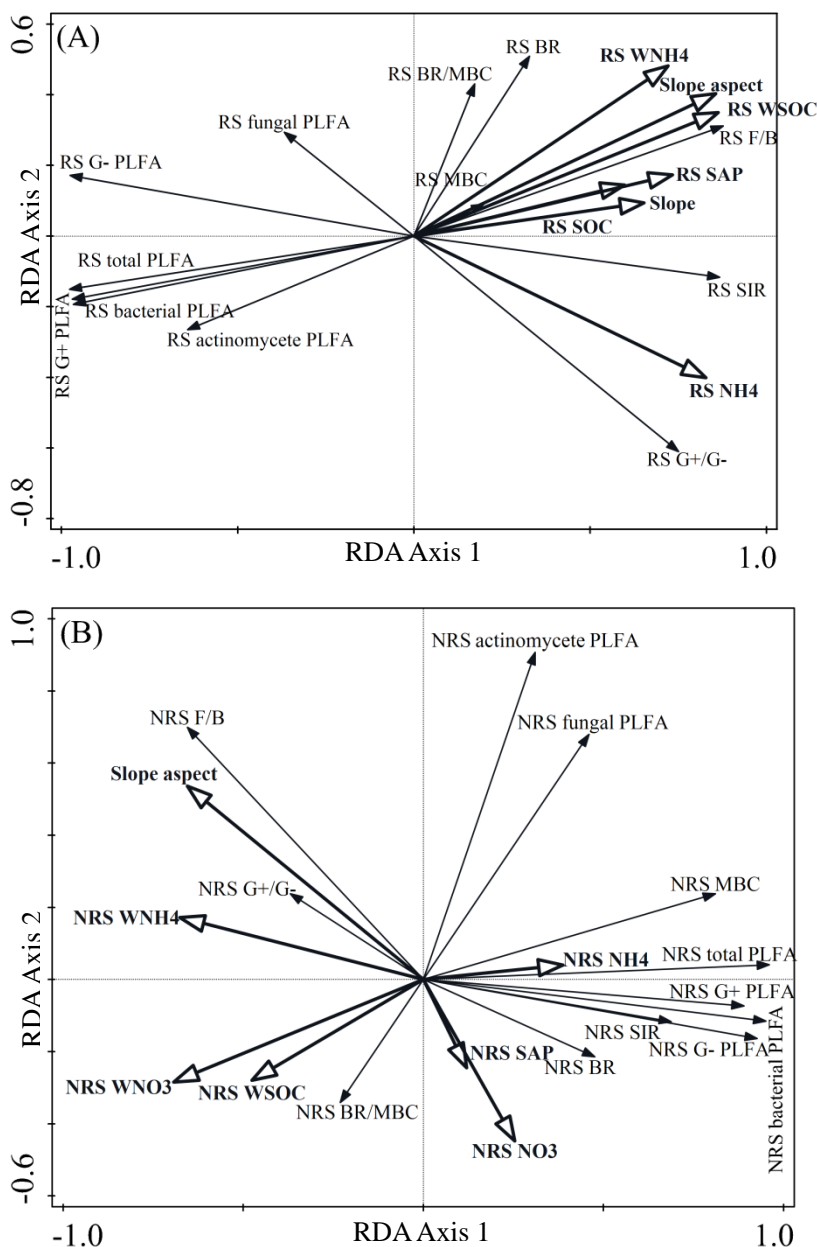

Fig. 4 Bidimensional graph for a redundancy analysis of the relationships between microbial properties and environmental factors in the rhizospheric (A) and non-rhizospheric (B) soils.

Note: RS, rhizospheric soil; NRS, non-rhizospheric soil; MBC, microbial biomass carbon; BR, basal respiration; SIR, substrate-induced respiration; F/B, the ratio of fungal PLFA content to bacterial PLFA content; G⁺/G⁻, the ratio of G⁺ PLFA content to G⁻ PLFA content; SAP, available phosphorus; SOC, soil organic carbon; NH₄, ammonium nitrogen; NO₃, nitrate nitrogen; WSOC, water-soluble organic carbon; WNH₄, water-soluble ammonium nitrogen; WNO₃, water-soluble nitrate nitrogen .

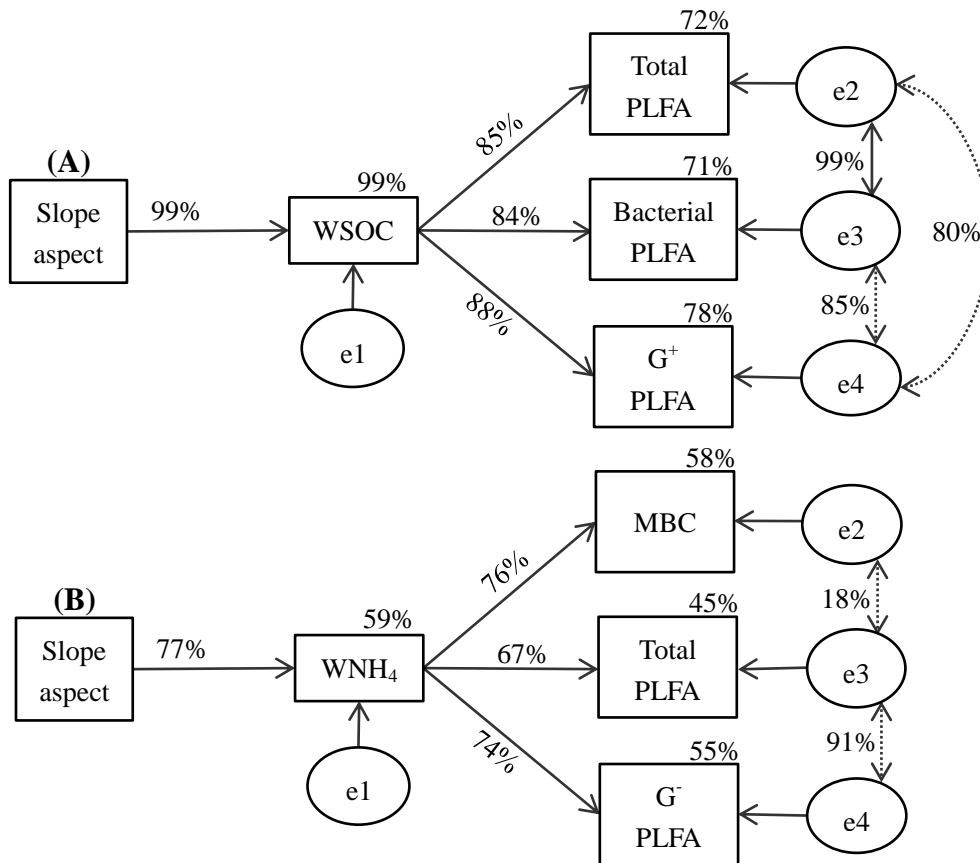

Fig. 5 Structural equation models of the effect of slope aspect on microbial properties in the rhizospheric (A) and non-rhizospheric (B) soils. Numbers on the arrows are standardised path coefficients (equivalent to correlation coefficients). Solid lines indicate significant standardised path coefficients ($P < 0.05$). Circles indicate error terms (e1–e4). Percentages near the endogenous variables indicate the variance explained by the model.